



# Operation and Maintenance Handbook

## AutroXT Extinguishant Control Panel BA-51/1

### Extinguishant Control Systems



Doc-1004878-2, 2022-05-18

COPYRIGHT ©

This publication, or parts thereof, may not be reproduced in any form, by any method, for any purpose.

Autronica Fire and Security AS and its subsidiaries assume no responsibility for any errors that may appear in the publication, or for damages arising from the information in it. No information in this publication should be regarded as a warranty made by Autronica Fire and Security. The information in this publication may be updated without notice.

Product names mentioned in this publication may be trademarks. They are used only for identification.



# Table of Contents

---

<b>1. Introduction</b> .....	<b>6</b>
1.1 About the handbook.....	6
1.2 The reader .....	7
1.3 Reference documentation.....	7
<b>2. CE mark</b> .....	<b>8</b>
<b>3. Safety</b> .....	<b>9</b>
3.1 General .....	9
3.2 Static precautions .....	9
3.3 Important Safety Information .....	10
3.4 National Standards and Regulations .....	11
3.5 Technical Documentation .....	11
3.6 System Design, Installation, Commissioning, Testing and Validation.....	12
3.7 Modifications to the products.....	12
3.8 Safety Notices.....	13
3.9 Compliance with Standards and Directives .....	13
3.10 Environment Compatibility .....	14
3.10.1 Recycling .....	14
3.10.2 Disposal.....	14
<b>4. Mounting</b> .....	<b>15</b>
<b>5. Technical specification</b> .....	<b>16</b>
5.1 Electrical specifications.....	16
5.2 Compatible sounders.....	17
<b>6. Front panel layout</b> .....	<b>18</b>
<b>7. Removing the equipment chassis</b> .....	<b>19</b>
<b>8. System setup</b> .....	<b>20</b>
8.1 System overview.....	20
<b>9. Connecting to the circuit board</b> .....	<b>21</b>
9.1 Sounder circuit wiring .....	23
9.2 Connection to extinguishant output .....	24
9.2.1 Solenoid wiring .....	24
9.2.2 Igniting actuator wiring .....	25
9.3 Connecting AutoXT to the detection loop.....	26
<b>10. Setting up extinguishant monitoring circuit</b> .....	<b>28</b>
<b>11. AUX 24VDC supply outputs</b> .....	<b>29</b>

<b>12.Connection to relay contacts.....</b>	<b>30</b>
12.1 Fault relay .....	30
12.2 1 <sup>st</sup> stage alarm relay (on extinguishing modules) .....	30
12.3 2nd stage alarm relay (on extinguishing modules).....	30
12.4 Released relay (on extinguishing modules).....	30
12.5 Aborted relay (on extinguishing modules) .....	31
12.6 Extract relay (on extinguishing modules).....	31
<b>13.Commissioning instructions .....</b>	<b>32</b>
13.1 Precautions before applying power .....	32
13.2 Testing after the power is applied.....	32
13.3 Configuration .....	32
13.4 Testing after configuration .....	32
13.5 Final connections .....	32
13.6 Recording the configuration.....	32
<b>14.Power supply.....</b>	<b>34</b>
<b>15.Internal controls .....</b>	<b>35</b>
15.1 Overview .....	35
15.2 Watchdog reset.....	35
15.3 Terminate extinguishant .....	35
15.4 Write enable switch.....	35
<b>16.Configuration.....</b>	<b>36</b>
16.1 Language selection.....	36
16.2 Extinguishant output mode .....	36
16.3 Configuring the activation mode .....	36
16.4 Configuring Stage 1 / Hold output .....	37
16.5 Multiple activation zones.....	37
16.6 Reset inhibit time .....	38
16.7 Pre-release delay time.....	38
16.8 Extinguishant release time.....	39
16.9 Second stage alarm pulsing/continuous.....	40
16.10 Released indication .....	40
16.11 Delay on manual release .....	41
16.12 Release timer (infinite duration).....	41
16.13 R0V not removed on reset.....	42
16.14 Disable earth fault monitoring .....	42
16.15 Disable fault output .....	43
16.16 Invert low pressure switch input.....	43
16.17 Extinguishant output monitoring levels .....	44

<b>17. Panel operation – Access levels 1 and 2</b>	<b>45</b>
17.1 Normal condition	45
17.2 Access level 2	45
17.2.1 Disable extinguishant release outputs	45
17.2.2 Disable Manual release	46
17.2.3 Disable Stage 1 output	46
17.2.4 Disable Stage 2 output	46
17.2.5 Disable Released output	47
17.2.6 Disable Extract output	47
17.2.7 Turn on Extract output	47
17.2.8 Select Reserve Solenoid output (configuration option)	48
17.3 Fire Alarm Condition	48
17.3.1 Single input activation	48
17.3.2 Double input activation	48
17.3.3 Manual release	49
17.4 Fault Condition	49
17.4.1 Sounder fault	49
17.4.2 Power fault	49
17.4.3 System fault	49
17.5 Released condition	50
17.6 Lamp test	50
17.7 Low pressure switch	50
17.8 Hold	50
17.9 Abort input	50
17.10 Reset	50
17.11 Manual Only mode	51
17.12 Function timeline chart	51
<b>18. Internal indications</b>	<b>52</b>
18.1 Watchdog	52
18.2 System fuse	52
18.3 Man. release	52
<b>19. Maintenance</b>	<b>53</b>

---

# 1. Introduction

---

## 1.1 About the handbook

AutroXT is designed in accordance with European standard EN 12094-1 Fixed firefighting systems - Components for gas extinguishing systems - Part 1: Requirements and test methods for electrical automatic control and delay devices.

The panel is a self-contained extinguishant release control panel that can receive activation signals at supervised inputs via volt free contacts from AutroSafe/Autroprime via addressable output modules.

AutroXT has an integral, mains powered, EN 54-4 compliant battery charger and power supply.

In addition to the requirements of EN 12094-1 AutroXT has the following facilities:

*Delay of extinguishing signal* of up to 60 seconds. EN 12094-1 Section 4.17: (option with requirements).

*Signal representing the flow of extinguishing agent* to indicate the released condition. EN 12094-1 Section 4.18: (option with requirements).

*Monitoring of the status of components* by way of a low pressure switch input. EN 12094-1 Section 4.19: (option with requirements).

*Emergency hold device* to enable the extinguishant delay time to be extended. EN 12094-1 Section 4.20: (option with requirements).

*Control of flooding time* to deactivate the releasing output after a set period of time. EN 12094-1 Section 4.21: (option with requirements).

*Manual only mode* to disable the release of extinguishant via automatic detection devices. EN 12094-1 Section 4.23: (option with requirements).

*Triggering of equipment outside the system* by way of first and second stage contacts, extract fan output etc. EN 12094-1 Section 4.26: (option with requirements).

*Activation of alarm devices with different signals* to indicate pre- discharge and released warnings using different sounds. EN 12094-1 Section 4.30: (option with requirements).

*Emergency Abort device* to inhibit the extinguishing signal until the emergency abort device has been de-activated and the panel has been reset. EN 12094-1 Section 4.27: (option with requirement).

## 1.2 The reader

This handbook is intended for consultants, sales personnel, potential customers and distributors.



## 1.3 Reference documentation

The table below shows an overview of the complete technical documentation that is available in several languages.

## 2. CE mark

All control panels have a label affixed to the inside of the lid as shown below.

This label should not be removed under any circumstances.

<b>Kentec Electronics Ltd. Dartford DA1 1JQ U.K.</b>		
<input type="text"/> <b>0086-CPD-96748</b>		
<p><b>EN12094-1</b>          Electrical automatic control and delay device.          Model Numbers: K21001M2, K21021M3, K21041M3,          K21042M3, K21081M3, K21082M3, K21083M4, K21084M4          Environmental Class A. Flooding Zones 1-4.          CO2-low-pressure, inert gas systems.  <b>Provided options:</b>          - Delay of extinguishing signal.          - Signal representing the flow of extinguishing agent.          - Monitoring of the status of components.          - Emergency hold device.          - Control of flooding.          - Manual only mode.          - Triggering of equipment outside the system.          - Activation of alarm devices with different signals.          Response delay activated condition maximum 3 sec.          Response delay triggering of outputs maximum 1 sec.          Install in accordance with Operation and Maintenance          manual Man-1112.          Power rating: 230V AC 1A 50Hz.          Mains terminal fuse (K21021, K21041, K21042, K21081,          K21082) - F1.6A L250V          Mains terminal fuse (K21001, K21083, K21084) -          F3A 250V TD 20mm</p>		
<p><b>Disconnect power before servicing.</b></p>		
W/O number:	<input type="text"/>	Date:
Operative:	<input type="text"/>	Tested:
B3226 Lab-1237		<input type="text"/>



## 3. Safety

---

### 3.1 General

Suppliers of articles for use at work are required under section 6 of the Health and Safety at Work act 1974 to ensure as reasonably as is practical that the article will be safe and without risk to health when properly used.

An article is not regarded as properly used if it is used 'without regard to any relevant information or advice' relating to its use made available by the supplier. This product should be installed, commissioned and maintained by trained service personnel in accordance with the following:

- IEE regulations for electrical equipment in buildings
- Codes of practice
- Statutory requirements
- Any instructions specifically advised by the manufacturer

According to the provisions of the Act you are therefore requested to take such steps as are necessary to ensure that you make any appropriate information about this product available to anyone concerned with its use.

This equipment is designed to operate from 230 V 50 Hz mains supplies and is of class 1 construction. As such it **must** be connected to a protective earthing conductor in the fixed wiring of the installation and a readily accessible double pole disconnect device meeting the requirements of EN 60950/IEC950 which disconnects live and neutral simultaneously shall be incorporated in the fixed wiring.

Switch disconnect devices such as MK Sentry 63 A or similar are suitable for this.

Failure to ensure that all conductive accessible parts of this equipment are adequately bonded to the protective earth will render the equipment unsafe.

This control panel is environmental class A and is designed for indoor use only at temperatures between -5 °C (+/- 3) and +40 °C (+/- 2) and with a maximum relative humidity of 95%.

The IP rating for the enclosure is IP30.

Operation outside of these limits may render the equipment unsafe.

### 3.2 Static precautions

Installation of the panel should be carried out by qualified personnel only. The electronic components within the panel are vulnerable to physical damage and damage by electrostatic discharges.

It is advisable to wear a wrist strap designed to prevent the build-up of static charges within the body, before handling any electronic circuit boards.

Never insert or remove boards or components with the power on.

---

## 3.3 Important Safety Information



IMPORTANT SAFETY INFORMATION. READ ENCLOSED WARNINGS AND SAFETY INFORMATION.

THIS MANUAL CONTAINS PRODUCT SAFETY WARNINGS, WARRANTY DISCLAIMERS, LIMITATIONS OF LIABILITY

### PRODUCT WARNINGS

THESE PRODUCTS ARE INTENDED FOR SALE TO, AND INSTALLATION BY, AN EXPERIENCED PROFESSIONAL. AUTRONICA FIRE AND SECURITY CANNOT PROVIDE ANY ASSURANCE THAT ANY PERSON OR ENTITY BUYING ITS PRODUCTS, INCLUDING ANY "AUTHORIZED DEALER", IS PROPERLY TRAINED OR EXPERIENCED TO CORRECTLY INSTALL FIRE RELATED PRODUCTS.

A PROPERLY INSTALLED AND MAINTAINED PRODUCT/SYSTEM MAY ONLY REDUCE THE RISK OF EVENTS SUCH AS FIRE, SMOKE; IT IS NOT INSURANCE OR A GUARANTEE THAT SUCH EVENTS WILL NOT OCCUR, THAT ADEQUATE WARNING OR PROTECTION WILL BE PROVIDED, OR THAT THERE WILL BE NO DEATH, PERSONAL INJURY, AND/OR PROPERTY DAMAGE AS A RESULT.

### AUTRONICA FIRE AND SECURITY

BATTERY OPERATED SENSORS, DETECTORS AND PANEL ACCESSORIES HAVE A LIMITED BATTERY LIFE. WHILE THESE PRODUCTS ARE DESIGNED TO PROVIDE SOME WARNING OF IMMINENT BATTERY DEPLETION THE ABILITY TO DELIVER SUCH WARNINGS IS LIMITED AND SUCH WARNINGS MAY NOT BE PROVIDED IN ALL CIRCUMSTANCES. PERIODIC TESTING OF THE SYSTEM IN ACCORANCE WITH THE INSTRUCTIONS PROVIDED IN THE USER MANUAL IS THE ONLY WAY TO ENSURE ALL SENSORS, DETECTORS AND PANEL ACCESSORIES ARE FUNCTIONING PROPERLY.

## WARRANTY DISCLAIMERS

TO THE MAXIMUM EXTENT PERMITTED BY LAW, AUTRONICA FIRE AND SECURITY HEREBY DISCLAIMS ALL WARRANTIES AND REPRESENTATIONS, WHETHER EXPRESS, IMPLIED, STATUTORY OR OTHERWISE INCLUDING (BUT NOT LIMITED TO) ANY WARRANTIES OF MERCHANTABILITY OR FITNESS FOR A PARTICULAR PURPOSE WITH RESPECT TO ITS PRODUCTS AND RELATED SOFTWARE. AUTRONICA FIRE AND SECURITY FURTHER DISCLAIMS ANY OTHER IMPLIED WARRANTY OF MERCHANTABILITY OR FITNESS.

AUTRONICA FIRE AND SECURITY MAKES NO REPRESENTATION, WARRANTY, COVENANT OR PROMISE THAT ITS PRODUCTS AND/OR RELATED SOFTWARE (I) WILL NOT BE HACKED, COMPROMISED AND/OR CIRCUMVENTED; (II) WILL PREVENT, OR PROVIDE ADEQUATE WARNING OR PROTECTION FROM, FIRE , SMOKE; OR (III) WILL WORK PROPERLY IN ALL ENVIRONMENTS AND APPLICATIONS.

## 3.4 National Standards and Regulations

Products from Autronica Fire and Security are developed and manufactured in compliance with international safety standards. Any additional national or local safety standards that apply where the equipment is installed and operated, must also be taken into account together with the safety regulations in the product documentation.

## 3.5 Technical Documentation



Anyone installing, commissioning, using or maintaining Autronica Fire and Security products must follow the instructions in this handbook and other applicable handbooks or standards in order to ensure safe operation of the products and services.

## 3.6 System Design, Installation, Commissioning, Testing and Validation



When installing and commissioning an Autronica system, including interfacing Autronica systems with external systems, the following applies:

- All equipment used for interfacing must comply with the intended purpose and specified ratings and limits (e.g., but not limited to, current, voltage or temperature limits) during both normal (e.g. standby or activation) and faulty operating conditions/modes (e.g. short circuit or break).
- Safety systems, including external interfaced systems and their status transmission paths (e.g. alarm, fault transmission or monitored input/outputs), must be tested according to applicable regulations (e.g. EN54, UL) to ensure proper operation during both normal and faulty operating conditions (e.g. short circuit or break).
- During system commissioning, to ensure that the system works as intended, the complete system (including, but not limited to the following: control panel, detectors, control functions, activation groups, activation of inputs/outputs and cause-and-effect configuration) must be tested and verified. The same applies when making changes to the system (e.g. changes to the loop setup and configuration or addition of alarm devices). Any part of the system affected by the changes must be tested to ensure normal and intended operation.
- During commissioning, system maintenance or similar, service personnel must take appropriate action in order to avoid unmotivated activation of outputs connected to safety-critical systems. Such actions may be, but is not limited to, SW disablement of outputs or physically disconnection of solenoids.



## 3.7 Modifications to the products



Modifications to the products mentioned in this handbook shall **not** be carried out. If a fault or malfunction occurs, the product in question shall be replaced with a new one. Contact your local Autronica contact or dealer for further information.

Autronica Fire and Security AS disclaims all liability or responsibility for any injuries or death, damage, faults, malfunctioning and safety risks that may occur due to the use of a product that has been modified.

## 3.8 Safety Notices

Safety Words	Symbol / Description
NOTICE	 Notifies people of important installation, operation, or maintenance information that is NOT HAZARD RELATED
CAUTION	 Indicates the presence of a hazard that will or could cause personal injury or property damage if ignored

## 3.9 Compliance with Standards and Directives

Our product portal <http://product.autronicafire.com/certificates/> provides information about certificates, standards and approval bodies.

---

## 3.10 Environment Compatibility

### 3.10.1 Recycling



The product is manufactured using materials and procedures which comply with current environmental protection standards EMC, RoHS, LVD and WEEE.

### 3.10.2 Disposal

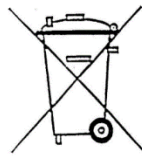

The WEEE Directive

The product is considered an electronic device for disposal in accordance with the European Guidelines. The device must be disposed through channels provided for this purpose.

The product should not be disposed with other household wastes at the end of its life cycle. During waste treatment, disposal and collection, please separate the product from other types of wastes and recycle it responsibly to promote the sustainable reuse of material resources. This product should not be mixed with other commercial wastes for disposal.

Make sure to comply with all local and currently applicable laws and regulations.

# 4. Mounting

AutroXT should be mounted on a dry, flat surface, at eye height to the display and in a level position such that the enclosure is not distorted.

Screws or bolts of a minimum of 5 mm diameter must be used to mount the enclosure in all three mounting positions. It should be positioned in an accessible place as agreed with the end user.

Suitable fixings should be used at all fixing points such that the unit is securely mounted and is not liable to move once fixed. AutroXT should not be mounted in another enclosure or near sources of excessive heat.

Cables should be connected using suitable cable glands fitted to the knockouts provided. If additional cable entry points are required, all swarf and debris caused by drilling of additional cable entries must be cleared before power is applied to the unit.

Cables should not be installed in the bottom of the enclosure. This space must be kept free for batteries.

AutroXT uses the H2 size enclosure, which is 385 mm W x 310 mm H x 110 mm D and is sufficient to house 7 Ah batteries.

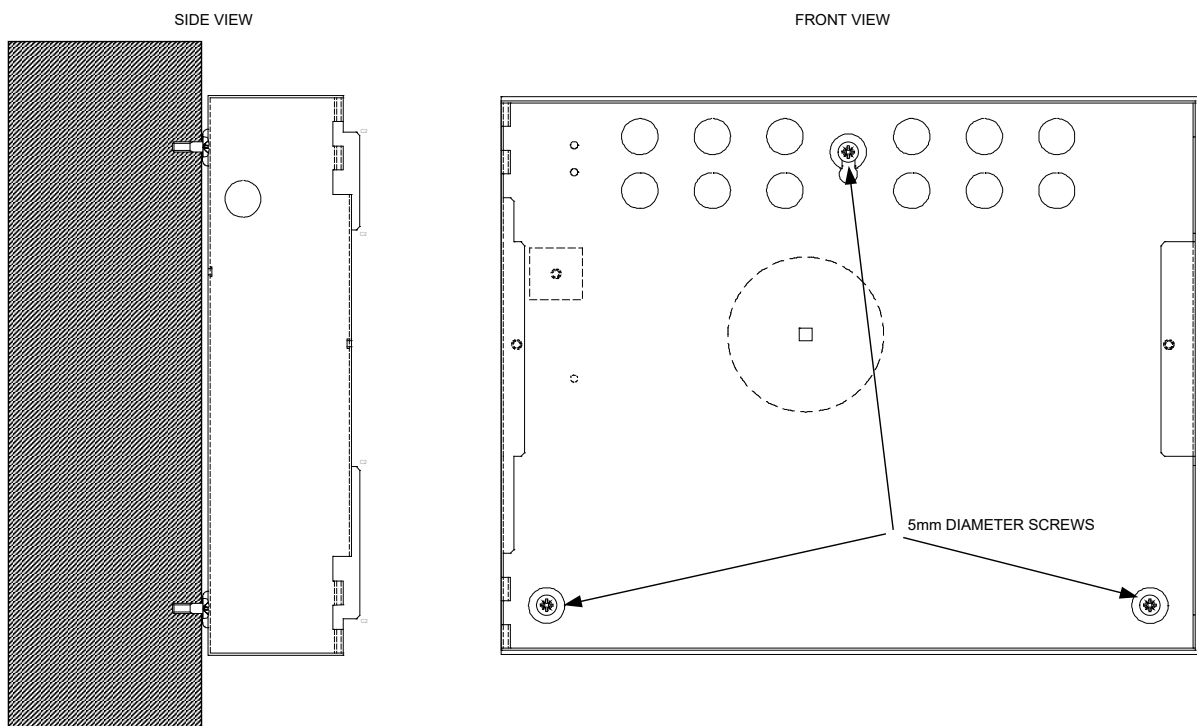

FIX TO FLAT SURFACE USING SUITABLE WALL PLUGS

# 5. Technical specification

## 5.1 Electrical specifications

Item	Electrical rating	Comment	Communication parameters
Mains supply	230 VAC, 50 Hz +10% - 15% (100 Watts maximum)		Standard European mains connection
Mains supply fuse	F3A 250 V TD 20 mm	Replace only with similar type	
Power supply rating	5 A when battery charging is not required	S406 power supply	
Maximum ripple current	1 V		
Battery type	2 x 12 Volt sealed lead acid in series		
Maximum Battery Capacity within Enclosure	7 Ah	Up to 26 Ah batteries supported by power supply (in mechanically coupled battery cabinet)	
Battery charge voltage	27.6 VDC nominal (temperature compensated)		Modulated DC
Battery charge current	1.25 A maximum		Modulated DC
I <sub>max a</sub>	4 A		
I <sub>max b</sub>	5 A		
R <sub>i max</sub>	1 R		
Current draw in mains fail condition	60 milliamps quiescent – 107 milliamps full alarm		
Maximum current draw from batteries	7 Amps	With main power source disconnected	
Aux 24 V output	Fused at 500 mA with electronic fuse	200 milliamp maximum continuous load	
1 <sup>st</sup> and 2 <sup>nd</sup> stage Sounder outputs	21 to 28 VDC, fused at 1 A with electronic fuse	1.0 Amp total load over <u>all</u> circuits	Voltage reversing DC
Fault relay contact rating	5 to 30 VDC 1 A Amp maximum for each	Maximum ratings not to be exceeded	Volt free changeover contact
First stage contact rating	5 to 30 VDC 1 A Amp maximum for each	Maximum ratings not to be exceeded	Volt free changeover contact
Second stage contact rating	5 to 30 VDC 1 A Amp maximum for each	Maximum ratings not to be exceeded	Volt free changeover contact
Extract contact rating	5 to 30 VDC 1 A Amp maximum for each	Maximum ratings not to be exceeded	Volt free changeover contact
Terminal capacity	0.5 mm <sup>2</sup> to 2.5 mm <sup>2</sup> solid or stranded wire		
Number of sounders per circuit	Dependent on type and current consumption	See table 2 for sounder types	
Monitored input end of line	6K8 +/- 5% ½ Watt resistor	Supplied in terminals	
Sounder circuit end of line	10 K +/- 5% ¼ Watt resistor	Supplied in terminals	
Extinguishant output end of line	1N4004 Diode	Supplied in terminals	
No. of sounder circuits (2)	21 to 28 VDC	1 x 1 <sup>st</sup> stage and 1 x 2 <sup>nd</sup> stage	
Extinguishant release outputs (2)	21 to 28 VDC. Fused at 1 Amp	1 Amp maximum load for 5 minutes 3 A for 20 milliseconds	Voltage reversing DC with calibration facility
Extinguishant release delay	Adjustable 0 to 60 seconds (+/- 10%)	5 second steps	
Extinguishant release duration	Adjustable 60 to 300 seconds	5 second steps	



Cabling	According to local requirements, i.e. FP200 or equivalent (maximum capacitance 1 uF max inductance 1 mH)	<i>Metal cable glands must be used</i>	
Monitored inputs normal threshold (Allowable EOL)	10K ohm to 2K ohm		
Monitored inputs alarm threshold	2K ohms to 150 ohms +/- 5%		
Monitored inputs Short circuit threshold	140 ohms to 0 ohms +/- 5%		
Status unit power output	21 to 28 VDC, fused at 500 mA with electronic fuse	<i>300 milliamp maximum load</i>	

Table 1: Electrical specifications

## 5.2 Compatible sounders

Model	Type	Manufacturer
Askari	Electronic	Cooper Fulleon
RoLP	Electronic	Cooper Fulleon
Squashni	Electronic	Cooper Fulleon
Symphoni	Electronic	Cooper Fulleon
BBR-7M	Electronic	Cooper Fulleon
BBR-24	Motorised	Cooper Fulleon

Table 2: Compatible sounders

## 6. Front panel layout

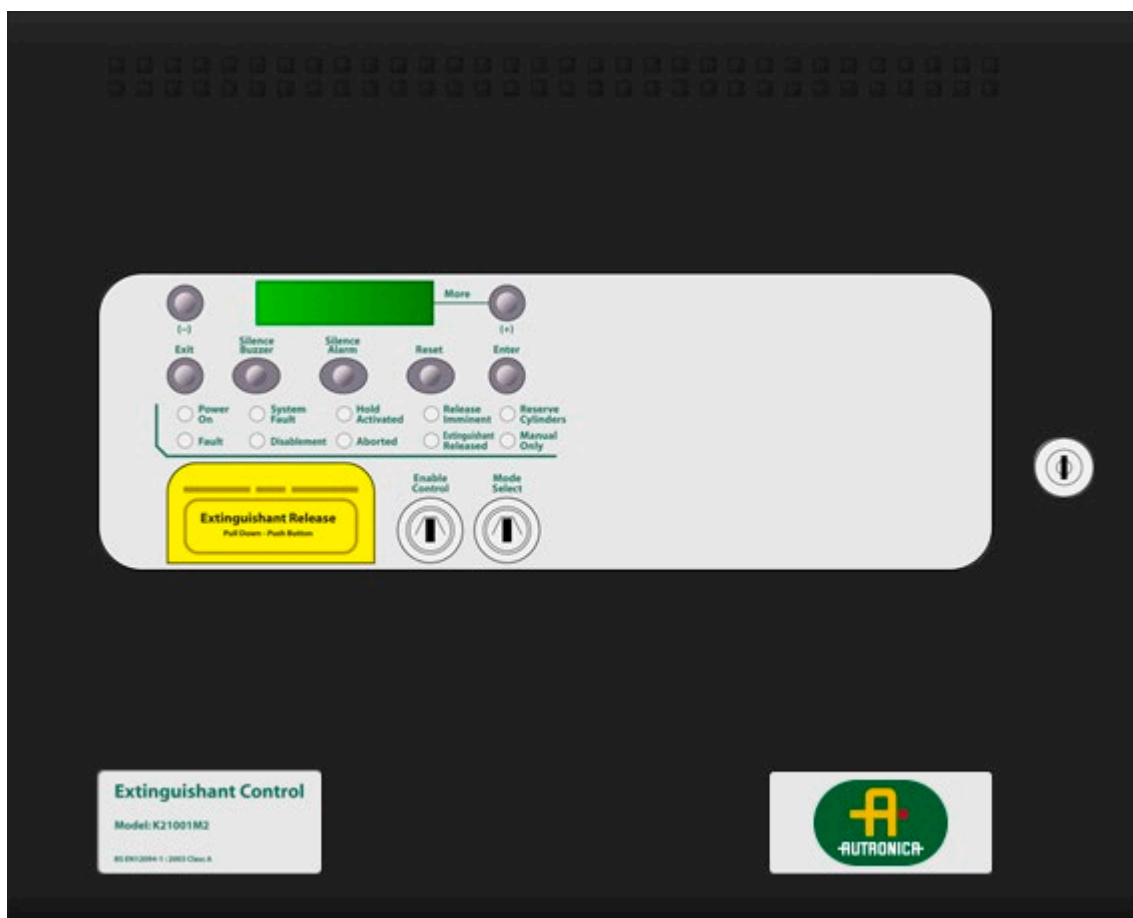

## 7. Removing the equipment chassis

Open the control panel lid using the 801 lock key.

Before the chassis can be removed it will be necessary to disconnect the power cables from connector terminal block on the left hand side of the PCB.

The chassis is held in place by two screws. Undo the two screws and lift the chassis gently away from the box towards you.

With the chassis removed, there is much more room inside the panel for making off and dressing cables.

When cabling work is complete, the chassis can be re-fitted and the power cables re-connected.

**IMPORTANT** -Ensure that the power cables are connected correctly.

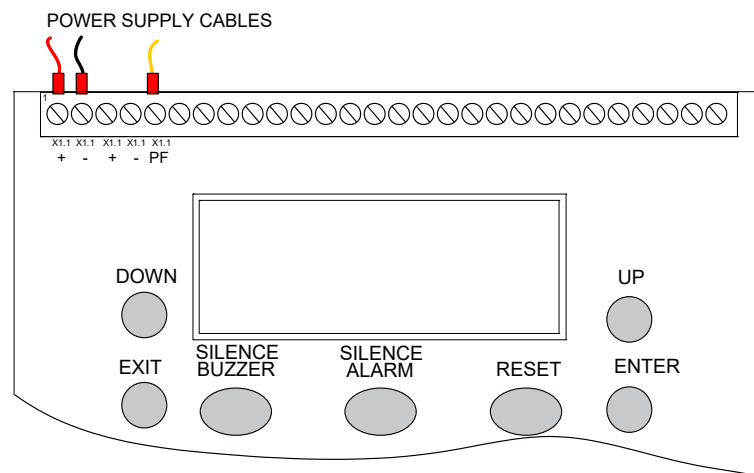

# 8. System setup

## 8.1 System overview

AutoXT connects to AutoSafe / AutoPrime via the detection loop. AutoXT uses addressable and monitored input/output modules for handling activation, fault and feedback.

Multiple zones can be achieved by connecting multiple AutoXT systems to the detection loop.

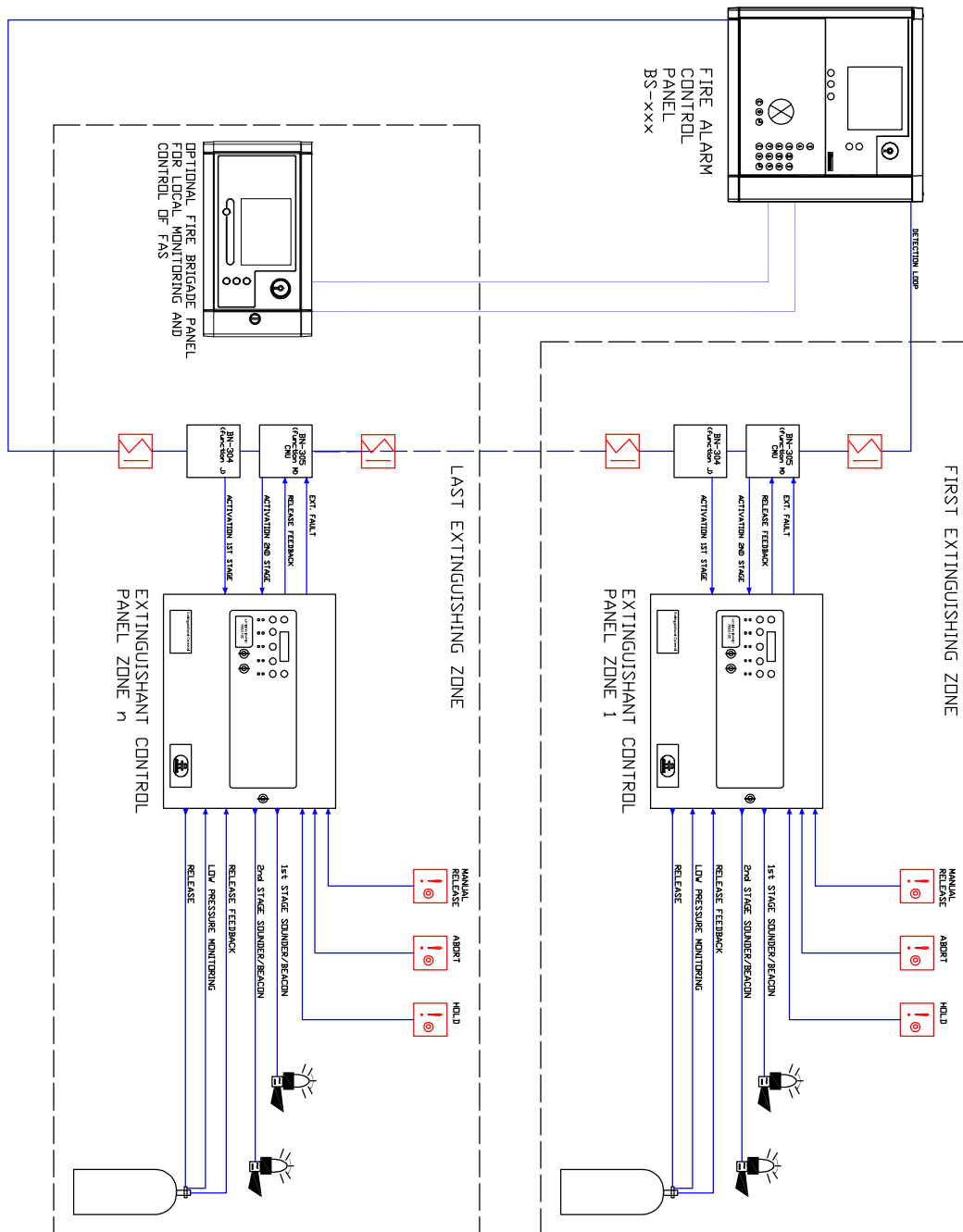

## 9. Connecting to the circuit board

---

All connections for field wiring are to rows of terminals along the top and bottom of the circuit board.

Consult local standards for information regarding cable requirements.

Wiring should enter the enclosure at the top or back of the panel using the knockouts provided and be formed tidily to the appropriate terminals.

Terminals are capable of accepting wires of up to 2.5 mm<sup>2</sup>.

Wiring must not go across the front of the circuit board. If cable entries need to be in positions other than at the knockouts provided, wiring must be fed behind and well away from the surface of the circuit board.

The space at the bottom of the enclosure is largely occupied by the standby batteries so this must be borne in mind when considering cable entries.

See terminal layout on next page.

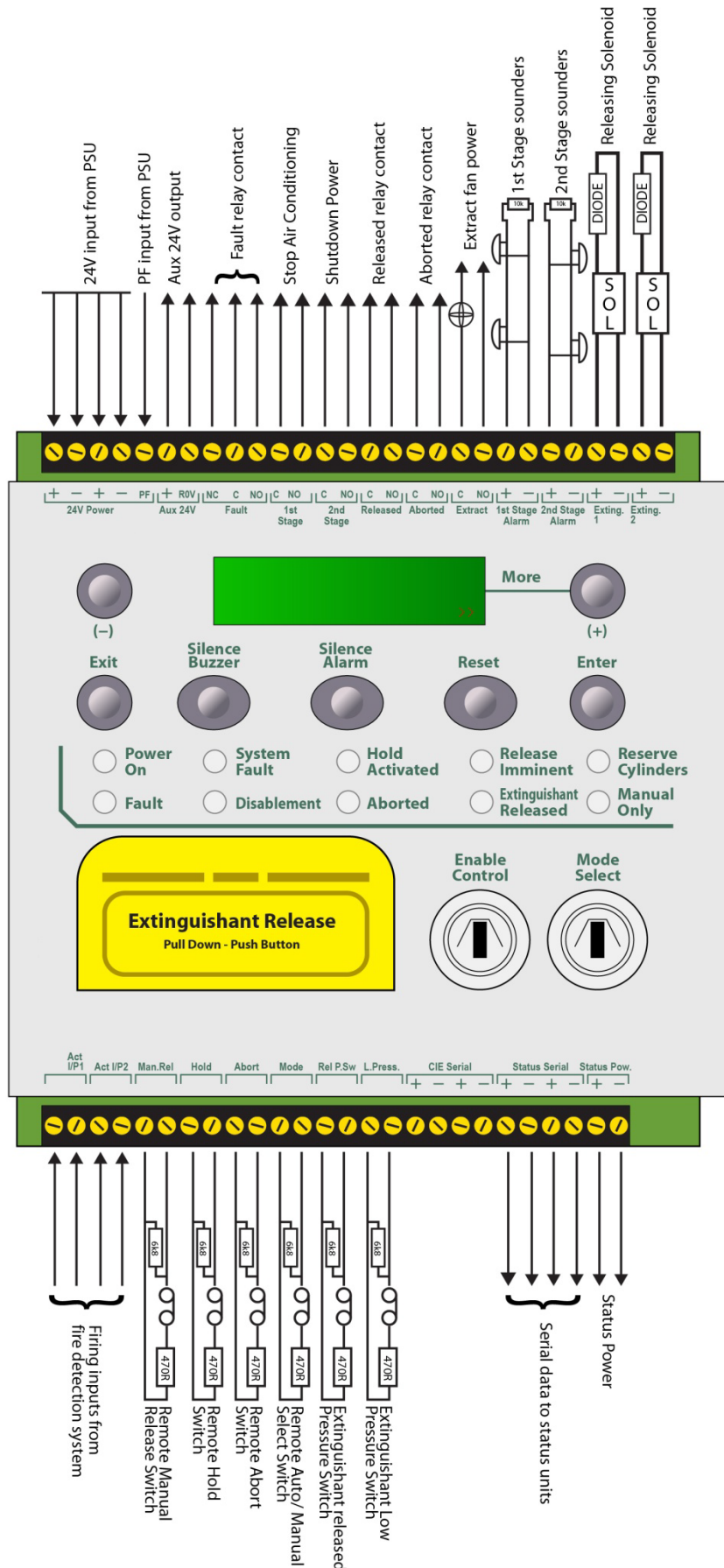

## 9.1 Sounder circuit wiring

All sounders must be of the polarised type. If non-polarised sounders are used the control panel will permanently show a fault condition. See table 2 for a list of compatible sounder types.

Sounder circuits are monitored for open and short circuit faults by placing a 10K 0.25 W end of line monitoring resistor across the last device on the circuit.

Sounder circuits must be wired as a single, radial circuit with no spurs or T junctions to enable the monitoring circuit to work correctly.

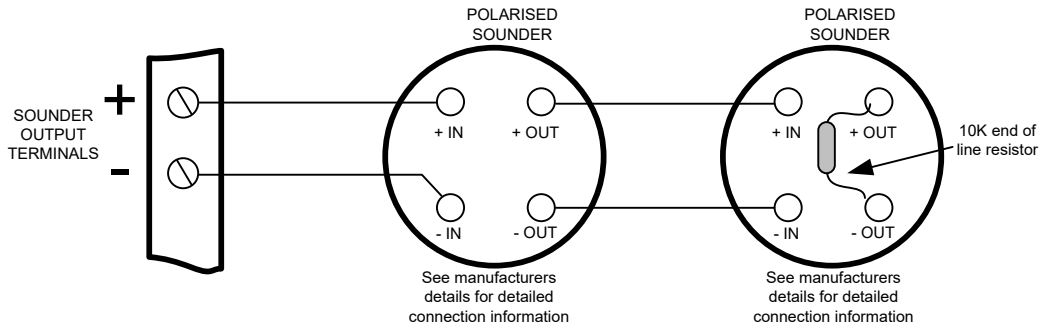

### Sounder circuit wiring through MTL7778ac I.S. barrier

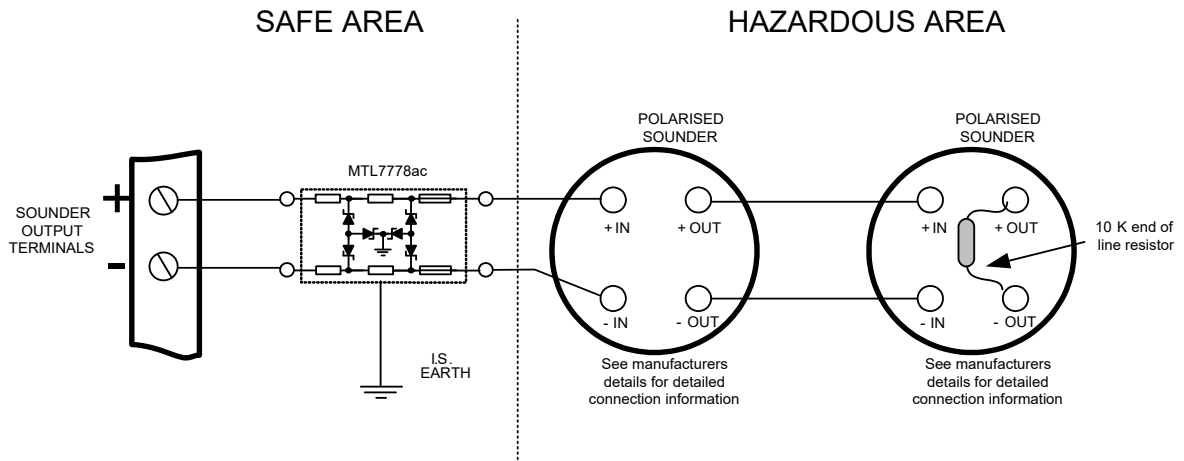

## 9.2 Connection to extinguishant output

The extinguishant output is capable of supplying up to 1 Amp for the maximum duration to a solenoid or 3 Amps for 20 milliseconds to an igniting actuator or Metron.

The wiring for solenoids and igniting actuators is different as shown below. Igniting actuators of different types or from different manufacturers should not be mixed on the same circuit.

### 9.2.1 Solenoid wiring

Solenoids must have a resistance of greater than 28 ohms to ensure that the maximum current rating of the extinguishant output is not exceeded.

Solenoids should be fitted with a suppression diode to prevent EMF generated by the solenoid when it de-energises from upsetting the operation of the control panel.

Only polarised solenoids (i.e. solenoids fitted with an internal polarising diode) should be used.

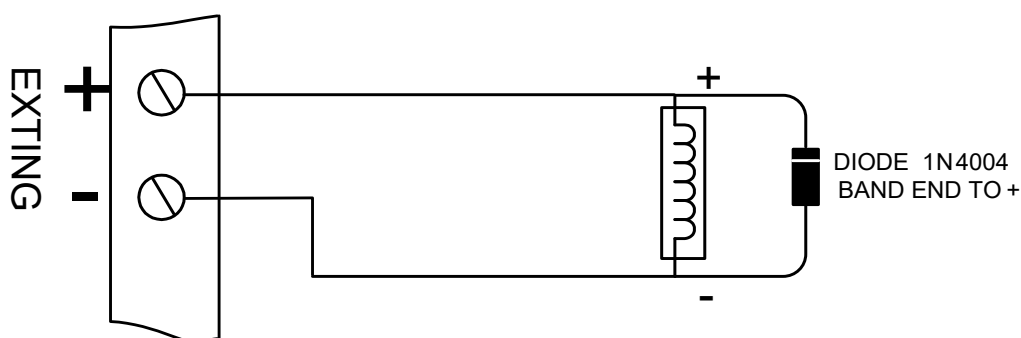

**Example of wiring a solenoid**

### Examples of compliant releasing valves

The extinguishant release output of the AutoXT is 1 Amp. All solenoids must operate using 1 amp or less.

#### Manufacturers Model

- ASCO HV2185328
- ASCO 8210G207
- Viking 11601
- Viking 11602
- Viking 11592
- Viking 11591
- Viking 11596
- Viking 11595
- Snap-Tite 2823A-2NB-A4F6



## 9.2.2 Igniting actuator wiring

A maximum of four igniting actuators can be wired in series. If only one or two actuators are fitted, a 2R2, 2.5 Watt resistor must be wired in series with them to provide the correct monitoring resistance. The end of line diode can be discarded when igniting actuators are used.

- To guarantee firing under all conditions, the total resistance of actuators, monitoring resistor and cable should not exceed 7 ohms.

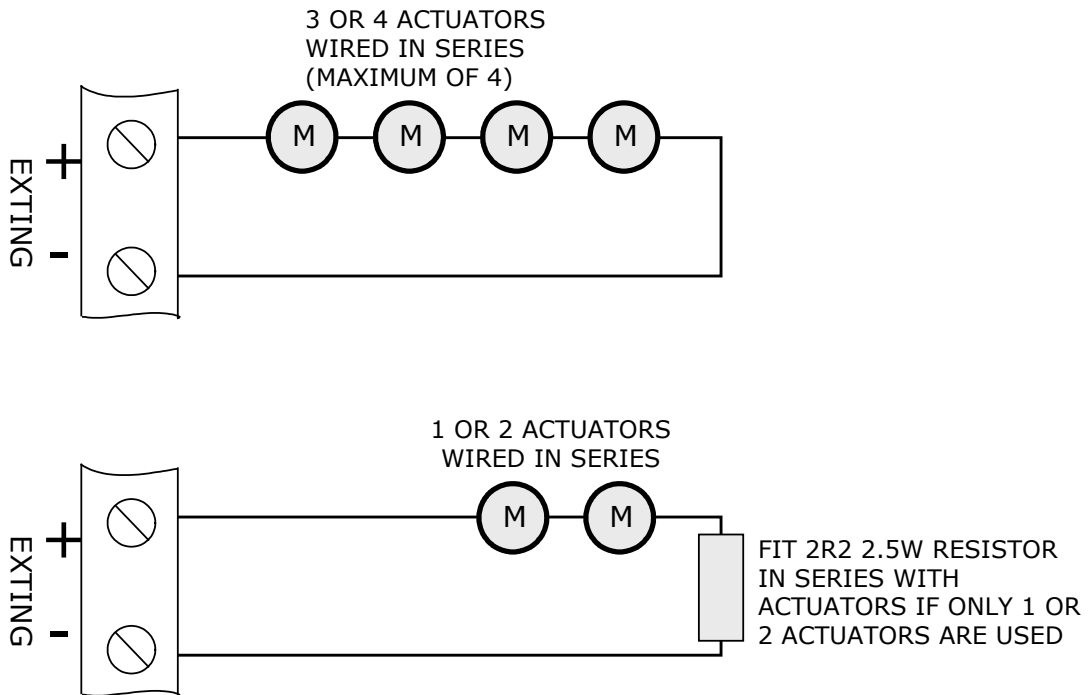

## 9.3 Connecting AutoXT to the detection loop

AutoXT has two monitored activation inputs which are used for connecting to the detection loop.

Wire volt free contacts from the addressable units on the detection loop from AutoSafe/Autoprime are shown on the drawing on the next page.

Consult the drawing and do the following connections:

- Connect the external output Fault signal to the monitored input of the BN-305 unit
- Connect the external Release Feedback signal to the monitored input of the BN-305 unit
- Connect the activation 1 signal from BN-304 to AutoXT's monitored Activation 1 input
- Connect the activation 2 signal from BN-305 to AutoXT's monitored Activation 2 input

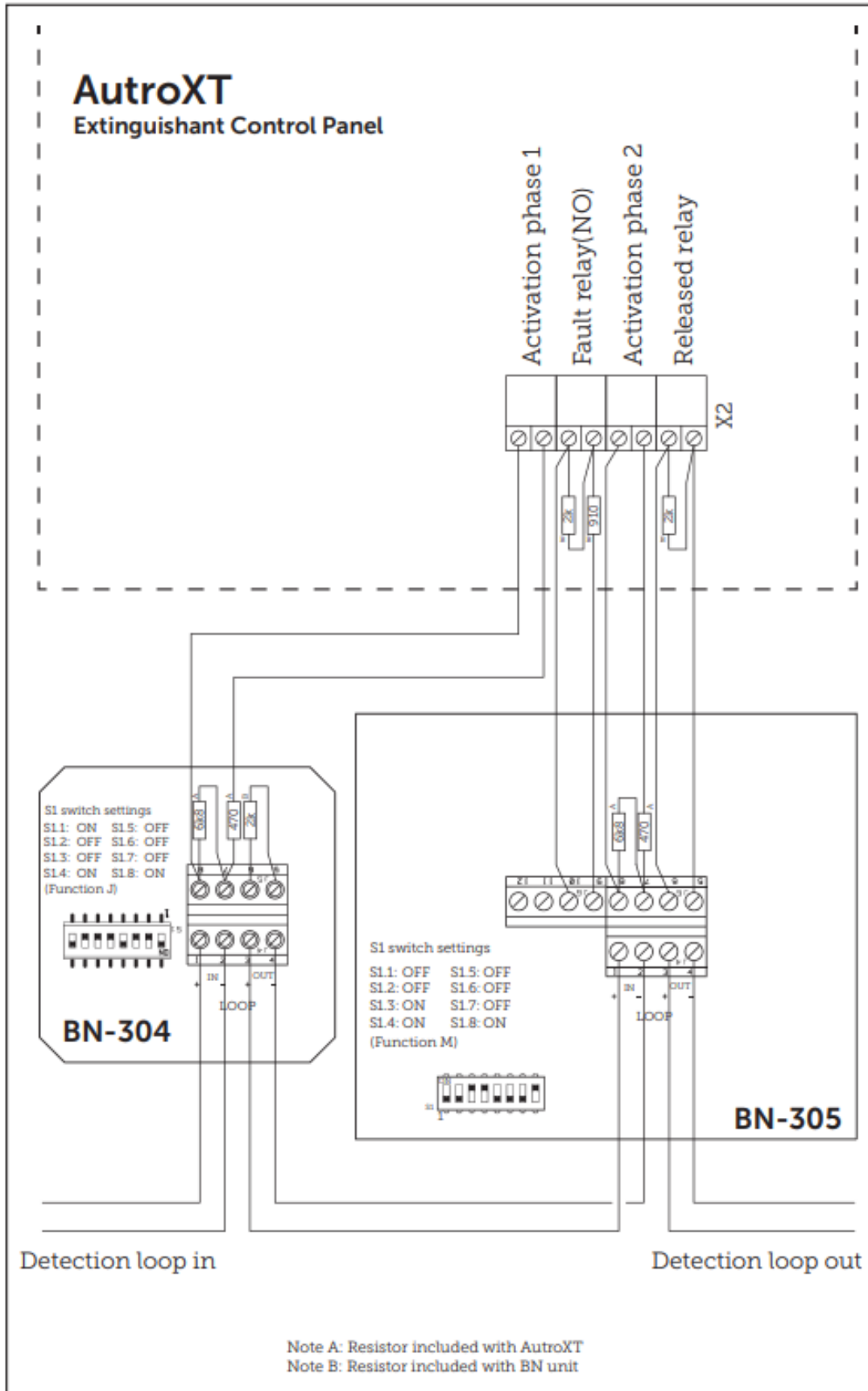

## 10. Setting up extinguishant monitoring circuit

The extinguishing output circuit is factory set to monitor the end of line diode that is fitted to the terminals and will normally show a value of around 270.

If the parameters of the extinguishant output change e.g. by connecting a solenoid in parallel with the monitoring diode or removing the diode and fitting igniting actuators, then the extinguishing output monitoring level will need to be "learnt". See section 14.16 for details. To do this, operate the enable controls key switch to put the system into access level 2.

The LCD will show:

Αχχεσσ λεπελ 2 ►  
ENTEΡ φορ Μενο

Operate the WRITE ENABLE switch by gently sliding it to the right. The LCD will show:

ΑΛ3 Υπδατεσ = ζζ  
ENTEΡ φορ Μενο

- Press the ENTER button and then the UP button repeatedly until the LCD displays:

Εξτινγ. Ο/Π 1  
Λεπελ = ΞΞΞ

The XXX displayed here is the previous (factory) level to which the monitoring level had been set.

- Press the ENTER button. The LCD will now show:

Εξτινγ. Ο/Π 1  
Λεπελ = ΞΞΞ ?

The XXX shown here is the current monitoring level detected on the extinguishing output. Press the ENTER button to learn the new monitoring level.

- Press the UP button to set the monitoring level for output 2 in the same way if it is being used, otherwise switch the write enable slide switch to the left (off) position and check that an open or short circuit fault on the extinguishing output(s) is detected and shown on the control panel.

# 11. AUX 24VDC supply outputs

---

The terminals for the Aux 24 V supply are labelled Aux 24 V + and R0V. The R0V terminal is the negative terminal.

It is possible to have the Aux 24 V supply outputs removed for a few seconds when the panel is reset.

This is set as default. To change this, switch the system to access level 2 by operating the enable control key switch and then operate the WRITE ENABLE switch by gently sliding it to the right.

The LCD will show:

ΑΛ3 Υπδατεσ = ξξ  
ENTER φορ Μενυ

- Press the ENTER button and then the UP button repeatedly until the LCD displays:

Ρ0ς Νοτ Ρεμοσεδ  
Ον Σψστεμ Ρεσετ

- Press the ENTER button. The LCD will now show:

Ρ0ς Νοτ Ρεμοσεδ  
Ον Σψστεμ Ρεσετ?

- Press the ENTER button. The LCD will now show:

Ρ0ς Ρεμοσεδ  
Ον Σψστεμ Ρεσετ

- Press the exit button.

The Aux 24 V supply outputs are fitted with an electronic, self-resetting fuse rated at 0.5 Amps to protect the control panel's 24 V supply in the event of a wiring fault.

Any standing load on the Aux 24 V supply outputs must be taken into account when calculating battery standby times as standby time will be significantly affected by even modest standing loads on these outputs. It is recommended that the Aux 24 V outputs are **not** used to power standing loads.

Where the Aux 24 V supply outputs are used to power electromechanical devices such as relays or door retainers it is imperative that a suppression diode is fitted across the coil of the device to prevent the generation of high voltage transients back to the control panel power supply.

---

## 12. Connection to relay contacts

---

Volt free changeover relay contacts are provided for local control and signalling if required. These contacts are rated for switching signalling circuits only and the maximum ratings listed in table 1 should not be exceeded under any circumstances.

Typically, the Aux 24 V output of the control panel is switched through these relays and used to control other systems.

### 12.1 Fault relay

The fault relay is normally energised and will de-energise upon any fault condition on the extinguishing module or total loss of power.

### 12.2 1<sup>st</sup> stage alarm relay (on extinguishing modules)

The first stage alarm relay will operate upon activation of a zone that has been configured to contribute to the extinguishant release or activation of one of the two monitored activation inputs and will de-activate only when the panel has been reset.

This relay will also operate upon activation of the panel mounted or a remote manual release switch. The stage 1 relay output can be disabled at access level 2 via the menus on AutoXT.

### 12.3 2nd stage alarm relay (on extinguishing modules)

The second stage alarm relay will operate when the panel enters the activated condition (i.e. the release countdown timer has started) and will de-activate only when the panel has been reset from the released condition.

The stage 2 relay output can be disabled at access level 2 via the menus on AutoXT.

### 12.4 Released relay (on extinguishing modules)

The released relay will operate when the module enters the released condition either by being activated automatically via detection zones, operation of the monitored activation inputs or by being activated by a manual release input.

**Part number of compliant release station (recommended):**  
116-4860-010.9008 REL.STATION SINGLE OPR. YELLOW

The released relay will also operate if the panel enters the released condition via the released pressure switch input.

The Released output can be disabled at access level 2 via the menus on AutoXT.

## 12.5 Aborted relay (on extinguishing modules)

Aborted relays will operate when the panel is in the aborted condition via an abort switch input.

## 12.6 Extract relay (on extinguishing modules)

The extract relay will operate when selected at access level 2. This provides a means to vent a room of extinguishant gases but prevents the gases from being vented during a discharge.

To switch on the extract relay, operate the enable key switch and then press ENTER on the module on which the required Extract relay is fitted.

The LCD will show:

ΔΙΣΑΒΛΕ  
ΕΞΤΙΝΓ ΡΕΛΕΑΣΕ ?

- Press the down button until the display shows:

ΤΥΡΝ ΟΝ  
ΕΞΤΡΑΧΤ ΟΥΤΠΙΥΤ ?

- Press ENTER to turn on the Extract output.

The display will show:

ΤΥΡΝ ΟΦΦ  
ΕΞΤΡΑΧΤ ΟΥΤΠΙΥΤ ?

- Pressing ENTER again will turn the extract output off.

---

# 13. Commissioning instructions

---

## 13.1 Precautions before applying power

Before applying power to the panel, any solenoids or igniting actuators must be physically isolated from the system by disconnecting both wires to it. This will prevent any accidental release of extinguishant.

## 13.2 Testing after the power is applied

When power is applied, if all connections are correct, only the green Power On and either the Automatic and Manual or Manual Only indicators should be lit. If any fault indicators are lit the wiring to the appropriate input or output should be checked and all faults cleared before proceeding.

## 13.3 Configuration

Once the panel is fault free, it can be configured with the desired options as described in section 15.

## 13.4 Testing after configuration

Once the panel has been configured the system should be thoroughly tested to ensure that the control panels respond as expected and required.

## 13.5 Final connections

After satisfactory testing, any final connections should be made (such as to the extinguishant release actuator).

## 13.6 Recording the configuration

A record of the configuration options that have been set on the detection part should be recorded in the table below and this manual provided as part of the documentation recommended by BS5839:Part 1:2002 section 40.2 b).

**Note:** If the Low pressure input is configured as INVERTED in the menu option, an error will display EXTING.PRESS.FAULT if the switch is not configured correctly.

The INVERTED input is looking for the 470 ohm trigger resistor to be removed on activation.



Configuration option	Write setting
Extinguishant output mode =	
ACTIVATION MODE =	
User O/p Mode =	
FIRST ACTIV. ZONE =	
LAST ACTV. ZONE =	
RESET INHIBIT TIME =	
PRE-REL. DELAY TIME =	
EXTING. RELEASE TIME =	
PULSED ACTIV. ALARMS ?	
STEADY ACTIV. ALARMS ?	
RELEASED IND. ON RELEASED INPUT ?	
RELEASED IND. ON EXTING RELEASE ?	
DELAY ON MANUAL RELEASE ?	
NO DELAY ON MANUAL RELEASE ?	
PRE-REL DELAY RESET ENABLED ?	
PRE-REL DELAY RESET DISABLED ?	
RELEASE TIMER ENABLED ?	
RELEASE TIMER DISABLED ?	
R0V NOT REMOVED ON SYSTEM RESET ?	
R0V REMOVED ON SYSTEM RESET ?	
EARTH FAULT ENABLED ?	
EARHT FAULT DIASLABLED ?	
FAULT OUTPUT ENABLED ?	
FAULT OUTPUT DISABLED ?	
LOW PRESS. I/P NORMAL ?	
LOW PRESS. I/P INVERTED ?	
EXTING. O/P 1 LEVEL =	
EXTING O/P 2 LEVEL =	

Table 3: Configuration options

# 14. Power supply

AutroXT requires a 230 V (+10%/-15%), 50/60 Hz, AC mains power supply which connects to the fused terminal block labelled “”.

AutroXT has a 20 mm T2A L250V mains fuse.

This fuse should only be replaced with fuses of the same or similar types.

The maximum loading on the power supply must be carefully considered when connecting externally powered equipment such as sounders and solenoids.

Exceeding the maximum power supply rating may cause a fuse or other protective device to operate and render the equipment inoperative until the fuse is replaced or protective devices are reset.

The table below can be used to calculate the loading for all models by adding the loads in the second column.

	Current in milliamps
ECU max alarm load	105
ECU module total sounder load	
ECU module extinguishant output load	
ECU module Aux 24 V supply	
TOTAL LOAD (must be less than 3 A)	

Table 4: Load calculation

The output voltage of the power supply is 28 VDC +/- 2 V and the total current rating is 4 A. The incoming mains cable should be routed well away from other lower voltage wiring by a distance of at least 50 mm.

Mains wiring should include an earth conductor, which is securely bonded to the building earth and should enter the enclosure as close as possible to the mains terminal block. Mains wires should be kept very short inside the enclosure and secured together close to the mains terminal block with a cable tie.

The maximum capacity batteries that can be fitted inside the enclosure are 7 Ah. These will provide sufficient capacity for 24 hours standby.

The maximum current drawn from the batteries when the main power source is disconnected is 4 Amps.

Battery leads are supplied wired to the power supply along with a link to connect the two batteries together.

**It is most important that the polarity of the batteries is carefully observed when connecting. Wrongly connected batteries could cause damage to the control panel.**

# 15. Internal controls

## 15.1 Overview

Note that address dipswitches are not to be used.

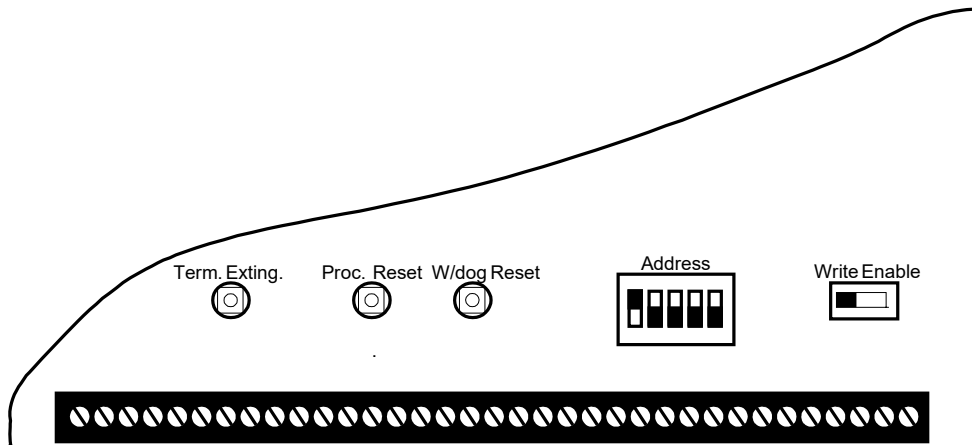

## 15.2 Watchdog reset

If the microprocessor on an ECU fails to carry out its operation correctly it will attempt to restart. AutoXT will show Fault and System Fault LEDs on the front panel, the buzzer will sound and the display will show CPU fault

This fault can only be cleared by pressing the Watchdog Reset button. The buzzer will continue to sound until the watchdog activation is reset.

## 15.3 Terminate extinguishant

Once the extinguishant outputs have been operated they cannot be switched off until after the reset inhibit timer has elapsed. For system test purposes (**not** to be used for fire drills) a terminate extinguishant button is provided which will terminate operation of the extinguishant outputs and allow the system to be reset.

## 15.4 Write enable switch

It is necessary to protect the configuration memory of AutoXT while the system is running normally. To do this a memory Write Enable switch is provided. The memory Write Enable switch must be switched on before any changes can be made to the configuration.

# 16. Configuration

## 16.1 Language selection

The module is capable of displaying two languages if factory programmed to do so. The first access level 3 option is to select the local language or the default language (English).

## 16.2 Extinguishant output mode

AutroXT has two extinguishing outputs. These can be configured to operate together at the same time (common) or be configured as main and reserve outputs.

The factory default setting for the extinguishing outputs is common.

- To change this, switch on the enable controls key switch and slide the write enable switch on the module to be configured gently to the left.
- Press the ENTER button on the extinguishing module. The display will show:

```
EXTING O/I MOΔE.  
= XOMMON
```

- Press the ENTER button and the display will show:

```
EXTING O/I MOΔE.  
= MAIN/PEΣEPÇE ?
```

- Press the ENTER button to select main/reserve.
- To save the settings, slide the write enable switch gently to the right.

When the extinguishing module is activated, only extinguishant output 1 will switch on.

There will also be an additional menu item at access level 2 to allow the reserve extinguishant output to be selected.

## 16.3 Configuring the activation mode

It is possible to configure the extinguishing modules to be activated by coincidence (both activation inputs) or a single zone in a range of zones or one of the activation inputs. The activation mode is factory set to coincidence.

- To change this, switch on the enable controls key switch and slide the write enable switch on the module to be configured gently to the left. Press the ENTER button on the extinguishing module then press the UP button. The display will show:

```
AXTIÇATION MOΔE.  
= XOINXIAENXE
```

- Press the ENTER button and the display will show:

ΑΧΤΙΣΑΤΙΟΝ ΜΟΔΕ.

= σινγλε ?

- Press the ENTER button to select single zone activation mode.
- To save the settings, slide the write enable switch gently to the right.

Operation of any of the zones in the range of zones selected to trigger the module (see below) will now put the module into the activated condition. Coincidence mode must not be set if single activation is required.

## 16.4 Configuring Stage 1 / Hold output

The '1<sup>st</sup> Stage' relay output is factory set to activate when as a stage 1 alarm contact, it can be re-configured to activate when the a 'Hold' input is activated.

- To change this, switch on the enable controls key switch and slide the write enable switch on the module to be configured gently to the left. Press the ENTER button on the extinguishing module then press the UP button. The display will show:

Υσερ Ο/π Μοδε

= Σταγε 1

- Press the ENTER button and the display will show:

Υσερ Ο/π Μοδε

= Ηολδ?

- Press the ENTER button to change mode.
- To save the settings, slide the write enable switch gently to the right.

## 16.5 Multiple activation zones

AutroXT can only handle one zone at the time. If multizone is needed, please refer to chapter 8.

AutroXT will not logically participate in more than one zone.

## 16.6 Reset inhibit time

It is a requirement of the standard EN 12094-1 to inhibit reset of the system after it has been activated until there is a signal representing the end of the discharge (a released input) or for an adjustable time period of up to 30 minutes. The factory default for the reset inhibit time is 0.

- To change the reset inhibit time, switch on the enable controls key switch and slide the write enable switch gently to the left.
- Press the ENTER button then press the UP button until the display shows:

ΡΕΣΕΤ ΙΝΗΙΒΙΤ  
ΤΙΜΕ = 0

- Press the ENTER button and the display will show:

ΡΕΣΕΤ ΙΝΗΙΒΙΤ  
ΤΙΜΕ = 0 ?

- To change the reset inhibit time, press the UP or DOWN buttons until the time required is displayed and then press ENTER.
- To save the settings, slide the write enable switch gently to the right.

Resetting of AutoXT after it has been activated will now be prohibited until the reset inhibit time that has been set.

## 16.7 Pre-release delay time

The standard EN 12094-1 allows for a time delay to be set from activation of AutoXT to operation of the extinguishing release output. This time may be between 0 and 60 seconds with a maximum of 5 second steps.

The factory default time delay on AutoXT is 30 seconds.

- To change the pre-release delay time, switch on the enable controls key switch and slide the write enable switch gently to the left. Press the ENTER button then press the UP button until the display shows:

πρε-ρελ δελαψ  
ΤΙΜΕ = 30 σεχ.

- Press the ENTER button and the display will show:

πρε-ρελ δελαψ  
ΤΙΜΕ = 30 σεχ.?

- To change the time, press the UP or DOWN buttons until the required time is displayed.
- To save the settings, slide the write enable switch gently to the right.

The pre-release delay time will now be set to the chosen value.

## 16.8 Extinguishant release time

The time that the extinguishant output is active for can be set between 60 and 300 seconds. The factory default time for this is 60 seconds. It is also possible to disable this timer such that the extinguishant outputs remain active until the module is reset. See Release timer menu option.

- To change the extinguishant release time, switch on the enable controls key switch and slide the write enable switch gently to the left. Press the ENTER button then press the UP button until the display shows:

```
ΕΞΤΙΝΓ. ΡΕΛΕΑΣΕ  
TIME = 60 σεχ.
```

- Press the ENTER button and the display will show:

```
ΕΞΤΙΝΓ. ΡΕΛΕΑΣΕ  
TIME = 60 σεχ. ?
```

- To change the time, press the UP or DOWN buttons until the required time is displayed
- To save the settings, slide the write enable switch gently to the right.

The extinguishing release time will now be set to the chosen value.

## 16.9 Second stage alarm pulsing/continuous

The second stage alarm output can be configured to be steady or pulsing at about 1 second on, 1 second off to suit the desired application.

The factory default for the second stage alarm is pulsing.

To change the operation of the second stage sounders, switch on the enable controls key switch and slide the write enable switch gently to the left.

- Press the ENTER button then press the UP button until the display shows:

```
ΠΥΛΣΕΔ
ΑΧΤΙς. ΑΛΑΡΜΣ
```

- Press the ENTER button and the display will show:

```
ΣΤΕΑΔΨ
ΑΧΤΙς. ΑΛΑΡΜΣ ?
```

- To change to steady second stage alarms, press the ENTER button.
- To save the settings, slide the write enable switch gently to the right.

The second stage alarm output will now be steady when the module is activated.

## 16.10 Released indication

It is possible to select whether the released indication is operated at the same time as the extinguishant release outputs operate or by operation of a pressure switch connected to the released, pressure switch input.

The factory default setting is for the released indication to be operated by operation of a pressure switch connected to the released, pressure switch input.

- To change the operation of the released indication, switch on the enable controls key switch and slide the write enable switch gently to the left. Press the ENTER button then press the UP button until the display shows:

```
ΡΕΛΕΑΣΕΔ ΙΝΔ ΟΝ
ΡΕΛΕΑΣΕΔ ΙΝΠΙΥΤ
```

- Press the ENTER button and the display will show:

```
ΡΕΛΕΑΣΕΔ ΙΝΔ ΟΝ
```

- To change to this, press the ENTER button.

```
ΕΞΤΙΝΓ. ΡΕΑ ?
```

- To save the settings, slide the write enable switch gently to the right.

The released indication will now be lit when the extinguishant outputs operate.



## 16.11 Delay on manual release

The manual release function (panel mounted and remote) can be configured to have a pre-release time delay (as per the set pre-release time) or to have no pre-release delay allowing immediate operation of the extinguishant outputs when a manual release is operated.

The factory default setting for this is for the manual release to have a delay time the same as the pre-release delay.

- To configure AutoXT to have no delay when a manual release is operated, switch on the enable controls key switch and slide the write enable switch gently to the left. Press the ENTER button then press the UP button until the display shows:

```
ΔΕΛΑΨ ON  
MANYAA PEΛΕΑΣΕ
```

- Press the ENTER button and the display will show:

```
NO ΔΕΛΑΨ ON  
MANYAA PEΛΕΑΣΕ ?
```

- To change to this, press the ENTER button.
- To save the settings, slide the write enable switch gently to the right.

Operation of a manual release will now operate the extinguishant outputs immediately with no delay.

## 16.12 Release timer (infinite duration)

The release timer can be disabled such that once the extinguishant outputs have operated; they remain operated until the system is reset.

To disable the release timer, switch on the enable controls key switch and slide the write enable switch gently to the left. Press the ENTER button then press the DOWN button until the display shows:

```
PEΛΕΑΣΕ TIMEP  
ENABΛΕΔ
```

- Press the ENTER button and the display will show:

```
PEΛΕΑΣΕ TIMEP
```

- To disable the release timer, press the ENTER button.

```
ΔΙΣΑΒΛΕΔ ?
```

- To save the settings, slide the write enable switch gently to the right.

With the release timer disabled, the extinguishant outputs will remain operated until the system is reset.

## 16.13 R0V not removed on reset

It is possible to configure the AUX 24 V output to be removed for a few seconds when the system is reset.

The factory default setting is for the AUX 24 V output not to be removed when the system is reset.

- To configure AutoXT such that AUX 24 V output is removed for a few seconds when the system is reset, switch on the enable controls key switch and slide the write enable switch gently to the left.
- Press the ENTER button then press the DOWN button until the display shows:

```
P0ς NOT PEMOςEA
ON ΣΨΣTEM PEΣET
```

- Press the ENTER button and the display will show:

```
P0ς PEMOςEA
ON ΣΨΣTEM PEΣET?
```

- To select this option, press the enter button.
- To save the settings, slide the write enable switch gently to the right.

With AutoXT configured to remove the R0V output on system reset, the Aux output will be removed for a few seconds when the reset button is pressed.

## 16.14 Disable earth fault monitoring

The earth fault monitoring facility can be disabled if required. The factory default setting is for the earth fault monitoring facility to be enabled.

- To disable the earth fault monitoring, switch on the enable controls key switch and slide the write enable switch gently to the left. Press the ENTER button then press the DOWN button until the display shows:

```
EARTH ΦAYAT
ENABAEΔ
```

- Press the ENTER button and the display will show:

```
EARTH ΦAYAT
ΔIΣABAEΔ ?
```

- To select this option, press the enter button.
- To save the settings, slide the write enable switch gently to the right.

The earth fault monitoring facility on AutoXT will now be disabled.

## 16.15 Disable fault output

The fault output relay can be disabled if required.  
The factory default setting is for the fault output relay to be enabled.

- To disable the fault output relay, switch on the enable controls key switch and slide the write enable switch gently to the left. Press the ENTER button then press the DOWN button until the display shows:

ΦΑΥΛΤ ΟΥΤΠΟΥΤ  
ENABΛΕΑ

- Press the ENTER button and the display will show:

ΦΑΥΛΤ ΟΥΤΠΟΥΤ  
ΔΙΣΑΒΛΕΑ ?

- To select this option, press the enter button.
- To save the settings, slide the write enable switch gently to the right.

The fault output relay on the module will now be disabled.

## 16.16 Invert low pressure switch input

To enable low pressure switches to be used which have normally closed rather than normally open contacts, it is possible to invert the low pressure switch input.

The factory default setting is for the low pressure switch input to use a normally open contact.

- To invert the low pressure switch input, switch on the enable controls key switch and slide the write enable switch gently to the left.
- Press the ENTER button then press the DOWN button until the display shows:

ΛΟΩ ΠΡΕΣΣ. Ι/Π  
ΜΟΔΕ = ΝΟΡΜΑΛ

- Press the ENTER button and the display will show:

ΛΟΩ ΠΡΕΣΣ. Ι/Π  
ΜΟΔΕ = ΙΝΣΕΡΤΕΑ ?

- To select this option, press the enter button.
- To save the settings, slide the write enable switch gently to the right.

The low pressure switch input will now require a normally closed contact via a 470R trigger resistor and 6K8 end of line resistor for correct supervision.

**Note:** If the Low pressure input is configured as INVERTED in the menu option, an error will display EXTING.PRESS.FAULT if the switch is not configured correctly.

The INVERTED input is looking for the 470 ohm trigger resistor to be removed on activation.

## 16.17 Extinguishant output monitoring levels

The extinguishant outputs are able to monitor both solenoid and igniting actuator releasing devices. This requires that the outputs be calibrated with the releasing device and the cable to it, fitted as it will be in the working system.

The extinguishant outputs are fitted with a 1N4004 diode at the factory and the default monitoring level will be set at approximately 206 but may be between 204 and 208.

Before calibrating the extinguishant outputs ensure that the releasing device is fitted to the cable as shown in section 10.

- To change the monitoring level for extinguishing output 2, switch on the enable controls key switch and slide the write enable switch gently to the left.
- Press the ENTER button then press the DOWN button until the display shows:

εξτινγ. ο/π 2  
λεπελ = 206

- Press the ENTER button and the display will show:

εξτινγ. ο/π 2

The XXX here will be the actual monitoring level read by the module.

λεπελ = ξξξ ?

- To save this setting press the ENTER button.
- To set the monitoring level for extinguishant output 1, press the DOWN button. The display will show:

εξτινγ. ο/π 1  
λεπελ = 206

- Press the ENTER button and the display will show:

εξτινγ. ο/π 1

The XXX here will be the actual monitoring level read by the module.

λεπελ = ξξξ ?

- To save this setting press the ENTER button.
- To save the settings, slide the write enable switch gently to the right.

The extinguishing output levels will now be set and any significant variation detected in the monitoring levels will be announced as and EXTING. O/P fault.

# 17. Panel operation – Access levels 1 and 2

---

## 17.1 Normal condition

Under normal conditions and in Manual & Auto mode, the unit will have only the green, *Power On* LED lit. With the ENABLE controls key switch off, LCD will show:

Μανναλ & Αυτο

When switched to Manual Only mode, the Manual only yellow LED will be lit and the display will show:

ΜανYAA MOΔE

AutroXT has 3 access levels. Access level 1 is available at all times and allows operation the Buzzer silence button and the Lamp test function by holding down the EXIT button for more than 2 seconds. Access level 2 is enabled after operation of the front panel mounted Enable Controls key switch and Access level 3 allows configuration options to be set following operation of the Write Enable switch while at access level 2 (Enable Controls key switch operated).

## 17.2 Access level 2

With the Enable Control key switch operated, the LCD will display:

Αγγεσσ λεπελ 2 ►  
ENTER φορ Μενυ

- Press the ENTER button to view the following menu options.

### 17.2.1 Disable extinguishant release outputs.

- To disable both of the extinguishant release outputs, press the UP button on the module while at access level 2.

The display will show:

ΔΙΣΑΒΛΕ  
ΕΞΤΙΝΓ. ΡΕΛΕΑΣΕ ?

- Press the Enter button to select this function. The display will show:

ENABΛΕ  
ΕΞΤΙΝΓ. ΡΕΛΕΑΣΕ ?

The yellow disabled LED on the module that has been disabled will be lit.

- Turn the Enable key switch off to leave the disablement active. To re-enable the extinguishant outputs repeat the procedure above.

## 17.2.2 Disable Manual release

- To disable all Manual release inputs (front panel mounted and remotely connected), press the UP button on the module while at access level 2 until the module displays:

ΔΙΣΑΒΛΕ  
μανυαλ ΡΕΛΕΑΣΕ ?

- Press the Enter button to select this function. The display will show:

εναβλε  
μανυαλ ΡΕΛΕΑΣΕ ?

The yellow disabled LED on the module that has been disabled will be lit.

- Turn the Enable key switch off to leave the disablement active. To re-enable the manual release facility repeat the procedure above.

## 17.2.3 Disable Stage 1 output

- To disable the 1<sup>st</sup> Stage relay output, press the UP button on the module while at access level 2 until the display shows:

ΔΙΣΑΒΛΕ  
σταγε 1 ουτπυτ ?

- Press the Enter button to select this function. The display will show:

ΕΝΑΒΛΕ  
ΣΤΑΓΕ 1 ΟΥΤΠΙΥΤ ?

The yellow disabled LED on the module that has been disabled will be lit.

- Turn the Enable key switch off to leave the disablement active. To re-enable the Stage 1 relay output repeat the procedure above.

## 17.2.4 Disable Stage 2 output

- To disable the 2<sup>nd</sup> Stage relay output, press the UP button on the module while at access level 2 until the display shows:

ΔΙΣΑΒΛΕ  
σταγε 2 ουτπυτ ?

- Press the Enter button to select this function. The display will show:

ΕΝΑΒΛΕ  
ΣΤΑΓΕ 2 ΟΥΤΠΙΥΤ ?

The yellow disabled LED on the module that has been disabled will be lit.

- Turn the Enable key switch off to leave the disablement active. To re-enable the Stage 2 relay output repeat the procedure above.

### 17.2.5 Disable Released output

- To disable the Released relay output, press the UP button on the module while at access level 2 until the display shows:

ΔΙΣΑΒΛΕ  
ρελεασεδ ουτπυτ ?

- Press the Enter button to select this function. The display will show:

ΕΝΑΒΛΕ  
ρελεασεδ ΟΥΤΠΙΥΤ ?

The yellow disabled LED on the module that has been disabled will be lit.

- Turn the Enable key switch off to leave the disablement active. To re-enable the Released relay output repeat the procedure above.

### 17.2.6 Disable Extract output

- To disable Extract relay output, press the UP button on the module while at access level 2 until the display shows:

ΔΙΣΑΒΛΕ  
εξτραχτ ουτπυτ ?

- Press the Enter button to select this function. The display will show:

ΕΝΑΒΛΕ  
εξτραχτ ΟΥΤΠΙΥΤ ?

The yellow disabled LED on the module that has been disabled will be lit.

- Turn the Enable key switch off to leave the disablement active. To re-enable the Extract relay output repeat the procedure above.

### 17.2.7 Turn on Extract output

- To turn on the extract relay output, press the DOWN button on the module while at access level 2 until the display shows:

ΤΥΡΝ ΟΝ  
ΕΞΤΡΑΧΤ ΟΥΤΠΙΥΤ

- Press the Enter button to select this function. The display will show:

ΤΥΡΝ ΟΦΦ  
ΕΞΤραΧΤ ΟΥΤΠΙΥΤ ?

The yellow disabled LED on the module that has been disabled will be lit.

- Turn the Enable key switch off to leave the Extract output active. To turn off the Extract output, repeat the procedure above.

Note: the extract output does not turn off when the module is reset.

## 17.2.8 Select Reserve Solenoid output (configuration option)

If the panel is configured for Main/Reserve solenoid operation (See section 14.1) then an additional menu option is given to select which output is used.

- To turn on the Reserve Solenoid output, press the UP button on the module while at access level 2 until the display shows:

```
ΣΕΛΕΧΤ ΡΕΣΕΡϚΕ
ΕΕΤΙΝΓ. ΟΥΤΗΠΥΤ
```

- Press the Enter button to select this function. The display will show:

```
ΣΕΛΕΧΤ ΜΑΙΝ
ΕΕΤΙΝΓ. ΟΥΤΗΠΥΤ ?
```

The yellow Reserve Cylinders LED indicator on the module will be lit.

- Turn the Enable key switch off to leave the Reserve solenoid output active. To revert to the Main solenoid output, repeat the procedure above.

Note: This menu option is not shown if the panel is configured to Common Solenoid mode.

## 17.3 Fire Alarm Condition

AutroXT is either controlled by manual activation or by input activation from AutroSafe/Autroprime as described.

### 17.3.1 Single input activation

Single input activation depends on the following triggering conditions:

- Single input activation is configured
- the first or second monitored activation input is triggered

In this case the activated LED on the module will flash and the first stage relay contact will operate. The first stage sounder output will operate and the display will show:

```
πρεαχτιπατεδ ►
```

- Pressing the Silence alarm button will turn off the 1<sup>st</sup> stage sounder output

### 17.3.2 Double input activation

Double input activation depends on all the following triggering conditions:

- double input activation is configured
- the first and second monitored activation inputs are triggered
- the unit switched to “Automatic and Manual” mode
- the Hold input is not active
- the Disable Extinguishant function has not been invoked

In this case the extinguishant module will respond as listed below:

#### Pre-release phase:

- The second stage alarm output and contact will operate.
- The Activated indicator will light continuously.



- The display will indicate Αχτιπατεδ and show the time remaining until release in seconds.

**Release condition:**

- The extinguishant output will operate after the configured delay time and for the configured duration.
- The display will show Αχτιπατεδ Δισχηραργινγ for the duration of the release time.

When activation inputs have operated and the activated condition is reached (i.e. the Activated indicator is lit) it shall not be possible to reset the unit until the Reset Inhibit timer has elapsed.

### 17.3.3 Manual release

AutroXT may be activated by Manual release inputs via the manual release control on the front panel or a remotely mounted Manual release control connected to the monitored manual release inputs.

Operation of any of these Manual release controls will immediately activate AutroXT and begin the pre-release timer (if the module is configured to have a time delay for Manual release inputs).

## 17.4 Fault Condition

### 17.4.1 Sounder fault

A fault on either of the sounder circuits will light the Fault LED and AutroXT will display:

σταγε 1 αλαρμσ  
φαυλτ

or

σταγε 2 αλαρμσ  
φαυλτ

### 17.4.2 Power fault

Failure of the mains power or disconnection of the standby battery will cause the *Fault* LED to light and the display will show:

ΠΟΩΕΡ ΣΥΠΠΙΛΨ  
ΦΑΥΛΤ

### 17.4.3 System fault

The System fault and general fault LEDs will light if the configuration memory has not been set or has become corrupted, or a fault has been detected on any of the monitored inputs.

## 17.5 Released condition

In this condition the extinguishant will be released, and the Released indicator on AutoXT will activate.

## 17.6 Lamp test

Indicators can be lamp tested by holding down the EXIT button for more than 2 seconds.

## 17.7 Low pressure switch

The low pressure switch input will be connected to a pressure switch on the extinguishant cylinder which will operate if the pressure in the cylinder falls below a set point. In case of a leakage, the Low pressure switch will cause a fault LED on AutoXT to activate and the buzzer will sound.

## 17.8 Hold

AutoXT has the facility for connection of an optional Hold control button. Activation of the Hold input (i.e. pushing and holding down the button) on AutoXT will cause the indicator “Hold Activated” to light, and the extinguishant release delay sequence to stop. 2<sup>nd</sup> stage sounders will change to 1 second on / 2 seconds off.

To re-initiate the fire alarm condition and restart the pre-release timer, release the button.

## 17.9 Abort input

AutoXT has the facility for connection of an optional Abort control (Abort Control Unit). Operation of the Abort input during the pre-release delay time or before activation will light the Abort indicator on AutoXT and the extinguishant release timer will be cancelled i.e. the extinguishant will not be released. AutoXT can be immediately reset from this condition.

## 17.10 Reset

In case of a fault condition (see chapter 12.1, 17.4.1, 17.4.2 and 17.4.3) the following reset procedure must be carried out to reset AutoXT:

1. Make sure any faults are properly corrected before attempting to reset from a fault condition.

From the AutoXT panel:

2. Enter operator level by turning the Enable Control key switch clockwise
3. Press the reset button
4. Leave operator level by turning the Enable Control key switch counter-clockwise

From the AutoSafe/Autoprime panel;

5. Reset the AutoSafe/Autoprime (see separate instructions for the system in question)

## 17.11 Manual Only mode

The mode of the system can be toggled between “Manual Only” and “Automatic & Manual” by operating the Mode select key switch.

When AutoXT is in “Manual Only” mode, the extinguishant cannot be released from AutoSafe/Autoprime (since the monitored activation inputs of AutoXT are disabled).

## 17.12 Function timeline chart

AutoXT Extinguishant Control Panel can be in one of the following conditions:

1. Quiescent
2. Pre-activation (Stage 1/Hold Output Phase)
3. Pre-release (Second Stage Alarm Pulsing/Continuous)
4. Released

The function timeline chart provides an overview of these different conditions and in which phase/sequence of the timeline the functions Reset, Hold and Abort can be performed.

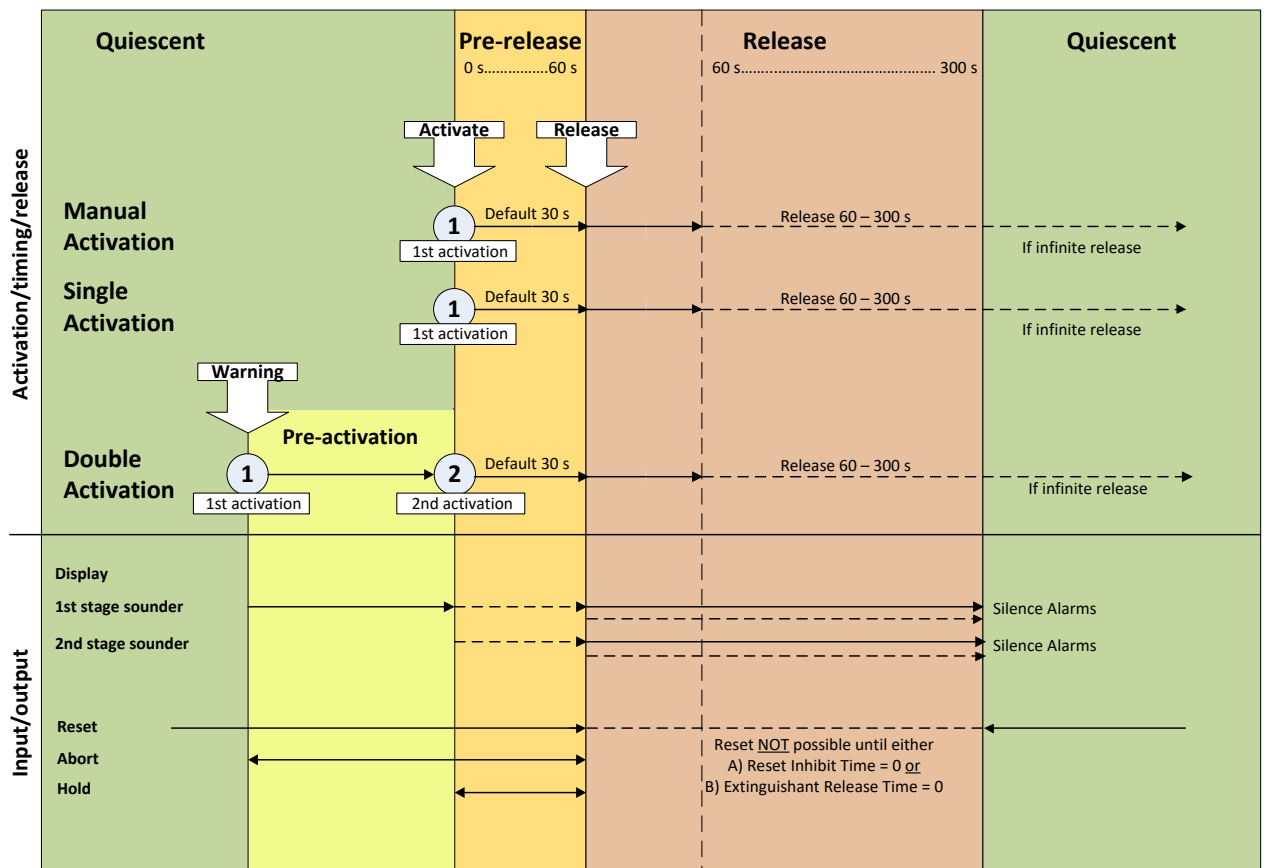

# 18. Internal indications

---

## 18.1 Watchdog

Indicates that the processor has failed to correctly execute and needs to be reset on the internal controls (see previous chapter).

## 18.2 System fuse

Indicates that the modules main fuse has been overloaded and the module is shut down. Remove and review all loads then re-connect one at a time.

## 18.3 Man. release

Indicates that either the front panel mounted or a remotely connected Manual release control has been operated. This indication can only be cleared by power cycling the module or pressing the processor reset switch.

# 19. Maintenance

---

AutroXT does not require any specific maintenance but should the control panel become dirty it can be wiped over with a barely damp cloth. Detergents or solvents should not be used to clean the panel and care must be taken that water does not enter the enclosure.

The control panel contains sealed lead acid batteries to provide standby power in the event of mains failure.

These batteries have an estimated life expectancy of 4 years. It is recommended that these batteries be tested in accordance with the battery manufacturer's recommendations annually to determine their suitability for continued standby applications.

Testing of the extinguishant system should only be carried out by trained personnel and must be done with appropriate isolation measures in place to ensure that accidental discharge of the extinguishant agent is avoided.

Should the control panel become faulty the complete electronic assembly and front plate can be replaced.

To do this, any configured options should be noted then both mains and battery power should be removed before the work is started.

The field wiring should be carefully labelled and removed from the terminals.

The faulty PCB plate assembly can now be taken out of the panel by removing the 2 screws.

Fitting the new PCB is the reverse of the procedure for removing the board.

